





# Chapter 5 Part A:

## Starting and charging systems

### Contents

Alternator - removal and refitting	6	Charging system - testing	5
Alternator brushes and voltage regulator - renewal	7	Electrical fault finding - general information	2
Auxiliary drivebelt check and renewal	See Chapter 1	General information, precautions and battery disconnection	1
Battery - removal and refitting	4	Starter motor - removal and refitting	9
Battery - testing and charging	3	Starter motor - testing and overhaul	10
Battery, bulbs and fuses	See "Weekly Checks"	Starting system - testing	8

### Degrees of difficulty

<b>Easy</b> , suitable for novice with little experience 	<b>Fairly easy</b> , suitable for beginner with some experience 	<b>Fairly difficult</b> , suitable for competent DIY mechanic 	<b>Difficult</b> , suitable for experienced DIY mechanic 	<b>Very difficult</b> , suitable for expert DIY or professional 
---	--	--	---	--

### Specifications

#### General

System type ..... 12 volt, negative earth

#### Battery

Rating - Cold cranking/Reserve capacity ..... 270 A/50 RC, 360 A/60 RC, 500 A/70 RC, 590 A/90 RC or 650 A/130 RC

Charge condition:

Poor ..... 12.5 volts

Normal ..... 12.6 volts

Good ..... 12.7 volts

#### Alternator

Make/type:

Bosch ..... K1-55A, K1-70A, KC-70A or KC-90A

Magneti-Marelli ..... A127/55 or 127/70

Mitsubishi ..... A5T or A002T

Output (nominal at 13.5 volts with engine speed of 6000 rpm) ..... 55, 70 or 90 amps

Regulating voltage at 4000 rpm engine speed and 3 to 7 amp load ... 14.0 to 14.6 volts

Minimum brush length ..... 5.0 mm

#### Starter motor

Make/type:

Bosch ..... DM, DW or EV

Magneti-Marelli ..... M79 or M80R

Nippondenso ..... No type numbers given

Minimum brush length:

Bosch and Magneti-Marelli ..... 8.0 mm

Nippondenso ..... 9.0 mm

#### Torque wrench settings

	Nm	lbf ft
Alternator mounting bolts	25	18
Alternator adjustment bolt	12	9
Alternator adjustment centre lockbolt	22	16
Adjuster link-to-mounting bracket bolt	12	9
Alternator pulley nut:		
With key	50	37
Without key	60	44
Starter motor mounting bolts	35	26
Starter motor support bracket bolt	25	18

## 1 General information, precautions and battery disconnection

### General information

The engine electrical system consists mainly of the charging and starting systems. Because of their engine-related functions, these components are covered separately from the body electrical devices such as the lights, instruments, etc (which are covered in Chapter 12). Information on the ignition system is covered in Part B of this Chapter.

The electrical system is of the 12-volt negative earth type.

The battery is of the low maintenance or "maintenance-free" (sealed for life) type and is charged by the alternator, which is belt-driven from the crankshaft pulley.

The starter motor is of the pre-engaged type incorporating an integral solenoid. On starting, the solenoid moves the drive pinion into engagement with the flywheel ring gear before the starter motor is energised. Once the engine has started, a one-way clutch prevents the motor armature being driven by the engine until the pinion disengages from the flywheel.

### Precautions

Further details of the various systems are given in the relevant Sections of this Chapter. While some repair procedures are given, the usual course of action is to renew the component concerned. The owner whose interest extends beyond mere component renewal should obtain a copy of the "Automobile Electrical & Electronic Systems Manual", available from the publishers of this manual.

It is necessary to take extra care when working on the electrical system to avoid damage to semi-conductor devices (diodes and transistors), and to avoid the risk of personal injury. In addition to the precautions given in "Safety first!" at the beginning of this manual, observe the following when working on the system:

*Always remove rings, watches, etc before working on the electrical system.* Even with the battery disconnected, capacitive discharge could occur if a component's live terminal is earthed through a metal object. This could cause a shock or nasty burn.

*Do not reverse the battery connections.* Components such as the alternator, electronic control units, or any other components having semi-conductor circuitry could be irreparably damaged.

If the engine is being started using jump leads and a slave battery, connect the batteries *positive-to-positive* and *negative-to-negative* (see "Jump starting"). This also applies when connecting a battery charger.

Never disconnect the battery terminals, the alternator, any electrical wiring or any test

instruments when the engine is running.

Do not allow the engine to turn the alternator when the alternator is not connected.

Never "test" for alternator output by "flashing" the output lead to earth.

Never use an ohmmeter of the type incorporating a hand-cranked generator for circuit or continuity testing.

Always ensure that the battery negative lead is disconnected when working on the electrical system.

Before using electric-arc welding equipment on the car, disconnect the battery, alternator and components such as the fuel injection/ignition electronic control unit to protect them from the risk of damage.

### Battery disconnection

Several systems fitted to the vehicle require battery power to be available at all times, either to ensure that their continued operation (such as the clock) or to maintain control unit memories (such as that in the engine management system's ECU) which would be wiped if the battery were to be disconnected. Whenever the battery is to be disconnected therefore, first note the following, to ensure that there are no unforeseen consequences of this action:

- a) *First, on any vehicle with central locking, it is a wise precaution to remove the key from the ignition, and to keep it with you, so that it does not get locked in, if the central locking should engage accidentally when the battery is reconnected.*
- b) *On cars equipped with an engine management system, the system's ECU will lose the information stored in its memory - referred to by Ford as the "KAM" (Keep-Alive Memory) - when the battery is disconnected. This includes idling and operating values, and any fault codes detected - in the case of the fault codes, if it is thought likely that the system has developed a fault for which the corresponding code has been logged, the vehicle must be taken to a Ford dealer for the codes to be read, using the special diagnostic equipment necessary for this. Whenever the battery is disconnected, the information relating to idle speed control and other operating values will have to be re-programmed into the unit's memory. The ECU does this by itself, but until then, there may be surging, hesitation, erratic idle and a generally inferior level of performance. To allow the ECU to relearn these values, start the engine and run it as close to idle speed as possible until it reaches its normal operating temperature, then run it for approximately two minutes at 1200 rpm. Next, drive the vehicle as far as necessary - approximately 5 miles of varied driving conditions is usually sufficient - to complete the relearning process.*
- c) *If the battery is disconnected while the alarm system is armed or activated, the alarm will remain in the same state when*

*the battery is reconnected. The same applies to the engine immobiliser system (where fitted).*

- d) *If a Ford "Keycode" audio unit is fitted, and the unit and/or the battery is disconnected, the unit will not function again on reconnection until the correct security code is entered. Details of this procedure, which varies according to the unit and model year, are given in the "Ford Audio Systems Operating Guide" supplied with the vehicle when new, with the code itself being given in a "Radio Passport" and/or a "Keycode Label" at the same time. Ensure you have the correct code before you disconnect the battery. For obvious security reasons, the procedure is not given in this manual. If you do not have the code or details of the correct procedure, but can supply proof of ownership and a legitimate reason for wanting this information, the vehicle's selling dealer may be able to help.*

Devices known as "memory-savers" (or "code-savers") can be used to avoid some of the above problems. Precise details vary according to the device used. Typically, it is plugged into the cigarette lighter, and is connected by its own wires to a spare battery; the vehicle's own battery is then disconnected from the electrical system, leaving the "memory-saver" to pass sufficient current to maintain audio unit security codes and ECU memory values, and also to run permanently-live circuits such as the clock, all the while isolating the battery in the event of a short-circuit occurring while work is carried out.



**Warning:** *Some of these devices allow a considerable amount of current to pass, which can mean that many of the vehicle's*

*systems are still operational when the main battery is disconnected. If a "memory-saver" is used, ensure that the circuit concerned is actually "dead" before carrying out any work on it!*

## 2 Electrical fault finding - general information

Refer to Chapter 12.

## 3 Battery - testing and charging



### Standard and low maintenance battery - testing

1 If the vehicle covers a small annual mileage, it is worthwhile checking the specific gravity of the electrolyte every three months to determine the state of charge of the battery. Use a hydrometer to make the check and compare the results with the following table.

	Ambient temperature above 25°C (77°F)	Ambient temperature below 25°C (77°F)
Fully-charged	1.210 to 1.230	1.270 to 1.290
70% charged	1.170 to 1.190	1.230 to 1.250
Fully-discharged	1.050 to 1.070	1.110 to 1.130

Note that the specific gravity readings assume an electrolyte temperature of 15°C (60°F); for every 10°C (18°F) below 15°C (60°F) subtract 0.007. For every 10°C (18°F) above 15°C (60°F) add 0.007.

**2** If the battery condition is suspect, first check the specific gravity of electrolyte in each cell. A variation of 0.040 or more between any cells indicates loss of electrolyte or deterioration of the internal plates.

**3** If the specific gravity variation is 0.040 or more, the battery should be renewed. If the cell variation is satisfactory but the battery is discharged, it should be charged as described later in this Section.

### Maintenance-free battery - testing

**4** In cases where a "sealed for life" maintenance-free battery is fitted, topping-up and testing of the electrolyte in each cell is not possible. The condition of the battery can therefore only be tested using a battery condition indicator or a voltmeter.

**5** If testing the battery using a voltmeter, connect the voltmeter across the battery and compare the result with those given in the *Specifications* under "charge condition". The test is only accurate if the battery has not been subjected to any kind of charge for the previous six hours. If this is not the case, switch on the headlights for 30 seconds, then wait four to five minutes before testing the battery after switching off the headlights. All other electrical circuits must be switched off, so check that the doors and tailgate are fully shut when making the test.

**6** If the voltage reading is less than 12.2 volts, then the battery is discharged, whilst a reading of 12.2 to 12.4 volts indicates a partially discharged condition.

**7** If the battery is to be charged, remove it from the vehicle (Section 4) and charge it as described later in this Section.

### Standard and low maintenance battery - charging

**Note:** *The following is intended as a guide only. Always refer to the manufacturer's recommendations (often printed on a label attached to the battery) before charging a battery.*

**8** Charge the battery at a rate of 3.5 to 4 amps and continue to charge the battery at this rate until no further rise in specific gravity is noted over a four hour period.

**9** Alternatively, a trickle charger charging at the rate of 1.5 amps can safely be used overnight.

**10** Specially rapid "boost" charges which are claimed to restore the power of the battery in

1 to 2 hours are not recommended, as they can cause serious damage to the battery plates through overheating.

**11** While charging the battery, note that the temperature of the electrolyte should never exceed 37.8°C (100°F).

### Maintenance-free battery - charging

**Note:** *The following is intended as a guide only. Always refer to the manufacturer's recommendations (often printed on a label attached to the battery) before charging a battery.*

**12** This battery type takes considerably longer to fully recharge than the standard type, the time taken being dependent on the extent of discharge, but it can take anything up to three days.

**13** A constant voltage type charger is required, to be set, when connected, to 13.9 to 14.9 volts with a charger current below 25 amps. Using this method, the battery should be usable within three hours, giving a voltage reading of 12.5 volts, but this is for a partially discharged battery and, as mentioned, full charging can take considerably longer.

**14** If the battery is to be charged from a fully discharged state (condition reading less than 12.2 volts), have it recharged by your Ford dealer or local automotive electrician, as the charge rate is higher and constant supervision during charging is necessary.

### 4 Battery - removal and refitting

**Note:** *Refer to the precautions in Section 1 before starting work.*

#### Removal

**1** The battery is located forward on the left-hand side of the engine compartment, on a platform welded to the vehicle structure.

**2** Undo the retaining nut, then detach the earth leads from the stud of the battery negative (earth) terminal post. This is the terminal to disconnect before working on, or disconnecting, any electrical component on the vehicle.

**3** Pivot up the plastic cover from the positive terminal, then unscrew the positive lead retaining nut on the terminal. Detach the positive lead from the terminal.

**4** Release the clamp securing the battery to its platform and remove it. Lift the battery from its location, keeping it in an upright position to avoid the possibility of corrosive electrolyte spilling onto the paintwork.

**5** Clean the battery terminal posts, clamps and the battery casing. If the bulkhead is rusted as a result of battery acid spilling onto it, clean it thoroughly and re-paint with reference to Chapter 1.

**6** If you are renewing the battery, make sure that you get one that's identical, with the same dimensions, amperage rating, cold cranking rating, etc. Dispose of the old battery in a responsible fashion. Most local authorities have facilities for the collection and disposal of such items - batteries contain sulphuric acid and lead, and should not be simply thrown out with the household rubbish!

### Refitting

**7** Refitting is a reversal of removal. Smear the battery terminals with a petroleum-based jelly prior to reconnecting. Always connect the positive terminal clamp first and the negative terminal clamp last.

### 5 Charging system - testing

**Note:** *Refer to the precautions in Section 1 before starting work.*

**1** If the ignition warning light fails to illuminate when the ignition is switched on, first check the alternator wiring connections for security. If satisfactory, check that the warning light bulb has not blown, and that the bulbholder is secure in its location in the instrument panel. If the light still fails to illuminate, check the continuity of the warning light feed wire from the alternator to the bulbholder. If all is satisfactory, the alternator is at fault and should be renewed or taken to an auto-electrician for testing and repair.

**2** If the ignition warning light illuminates when the engine is running, stop the engine and check that the drivebelt is correctly tensioned (see Chapter 1) and that the alternator connections are secure. If all is so far satisfactory, have the alternator checked by an auto-electrician for testing and repair.

**3** If the alternator output is suspect even though the warning light functions correctly, the regulated voltage may be checked as follows.

**4** Connect a voltmeter across the battery terminals and start the engine.

**5** Increase the engine speed until the voltmeter reading remains steady; the reading should be approximately 13.5 to 14.6 volts.

**6** Switch on as many electrical accessories (eg, the headlights, heated rear window and heater blower) as possible, and check that the alternator maintains the regulated voltage at around 13 to 14 volts.

**7** If the regulated voltage is not as stated, the fault may be due to worn brushes, weak brush springs, a faulty voltage regulator, a faulty diode, a severed phase winding or worn or damaged slip rings. The alternator should be renewed or taken to an auto-electrician for testing and repair.



6.3 Removing the drivebelt splash guard (where fitted)

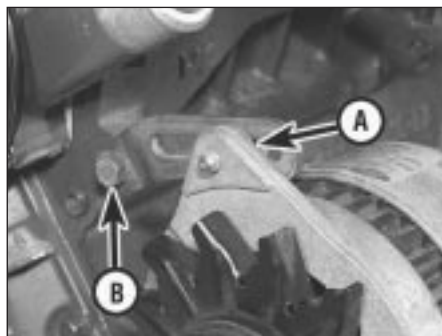

6.5 Alternator sliding arm type adjuster strap

A Adjuster bolt  
B Adjuster bracket to engine bolt

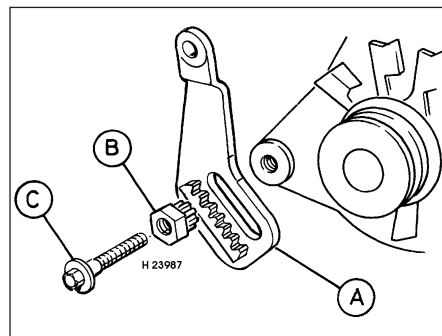

6.6 Rack-and-pinion type drivebelt adjuster

A Adjuster arm C Central (locking) bolt  
B Pinion (adjuster) nut

## 6 Alternator - removal and refitting



### Removal

- 1 Disconnect the battery negative (earth) lead (refer to Section 1).
- 2 Chock the rear wheels then jack up the front of the car and support it on axle stands (see "Jacking and vehicle support").
- 3 Where applicable, undo the retaining bolts and remove the drivebelt splash guard (see illustration).
- 4 On models with power steering and a separate drivebelt, remove the auxiliary (power steering pump) drivebelt as described in Chapter 1.

### Alternator with manual adjustment drivebelt

- 5 On models fitted with a sliding arm type adjuster strap, unscrew and remove the top (adjuster) bolt from the strap (see illustration).
- 6 On models fitted with a "rack-and-pinion" type adjuster, unscrew and remove the central (locking) bolt whilst, at the same time, loosening the (adjuster) nut (see illustration).
- 7 Loosen off, but do not yet remove,

the lower mounting bolts, pivot the alternator inwards towards the engine to slacken the tension of the drivebelt, then disengage the drivebelt from the pulleys and remove it.

- 8 Where applicable, detach and remove the alternator splash cover/heat shield (see illustration).
- 9 Where applicable, detach and remove the phase terminal and the splash cover.
- 10 Supporting the weight of the alternator from underneath, unscrew and remove the mounting bolts. Lower the alternator; noting the connections, detach the wiring and remove the alternator from the vehicle (see illustration).

### Alternator with automatic adjustment drivebelt

- 11 Remove the heatshield (if fitted) and disconnect the alternator wiring.
- 12 Fit a ring spanner onto the drivebelt tensioner, and rotate it clockwise to loosen off the tension from the drivebelt (see illustration). Note the routing of the drivebelt, then disengage the belt from the pulleys and remove it.
- 13 On pre-1994 model year Zetec engines, disconnect the oxygen sensor wiring multi-plug, then undo the two nuts and separate the exhaust downpipe from the manifold. Support

the downpipe to avoid straining the exhaust system mountings.

- 14 On all models, unscrew the alternator upper mounting bolts/nuts and disconnect the alternator wiring. Unscrew the lower bolts/nuts and remove the alternator from the engine. On pre-1994 Zetec engines, it will be necessary to de-tension the drivebelt tensioner to provide clearance for removal of the upper mounting bolt nut.

### Refitting

- 15 Refit in the reverse order of removal. Refit the drivebelt, and ensure that it is correctly routed around the pulleys. Adjust the tension of the drivebelt (according to type) as described in Chapter 1.

## 7 Alternator brushes and voltage regulator - renewal



- 1 Disconnect the battery negative (earth) lead (refer to Section 1).
- 2 Remove the alternator from the vehicle as described in the previous Section.

### Bosch

- 3 Remove the two screws securing the combined brush box/regulator unit, and



6.8 Removing the splash cover from the inner end of the alternator



6.10 Wiring loom routing on rear of alternator (CVH engine)

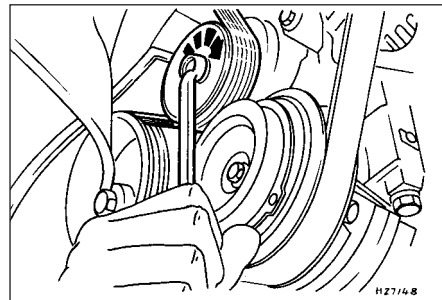

6.12 Automatic drivebelt tensioner

Turn tensioner clockwise to release drivebelt tension



7.3a Undo the retaining screw and . . .



7.3b . . . withdraw the brush box/regulator unit (Bosch alternator)



7.4 Measuring the brush lengths (Bosch alternator)



7.7a Removing the regulator and brushbox assembly securing screws (Magneti-Marelli alternator)



7.7b Disconnecting the field connector (Magneti-Marelli alternator)

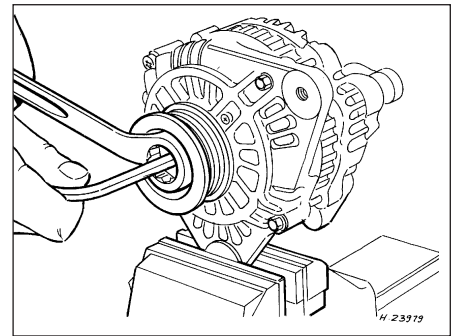

7.11 Pulley nut removal on the Mitsubishi alternator

withdraw the assembly from the rear of the alternator (see illustrations).

4 Check the brush lengths (see illustration). If either is less than, or close to, the minimum specified length, renew them by unsoldering the brush wiring connectors and withdrawing the brushes and their springs.

5 Clean the slip rings with a solvent-moistened cloth, then check for signs of scoring, burning or severe pitting. If evident, the slip rings should be attended to by an automobile electrician.

6 Refit in the reverse order of removal.

**Magneti-Marelli**

7 Remove the three screws securing the regulator/brush box unit on the rear face of the alternator, partially withdraw the assembly, detach the field connector, and remove the unit from the alternator (see illustrations).

8 If the brushes are worn beyond the minimum allowable length specified, a new regulator and brush box unit must be fitted; the brushes are not available separately.

9 Clean the slip rings with a solvent-moistened cloth, then check for signs of scoring, burning or severe pitting. If evident, the slip rings should be attended to by an automobile electrician.

10 Refit in the reverse order of removal.

**Mitsubishi**

11 Hold the pulley nut stationary using an 8 mm Allen key, unscrew the pulley nut and remove the washer (see illustration).

12 Withdraw the pulley, cooling fan, spacer and dust shield from the rotor shaft.

13 Mark the relative fitted positions of the front housing, stator and rear housing (to ensure

correct re-alignment when reassembling). Unscrew the through-bolts and remove the front housing from the rotor shaft, followed by the dust seal and the thin spacer (see illustrations).

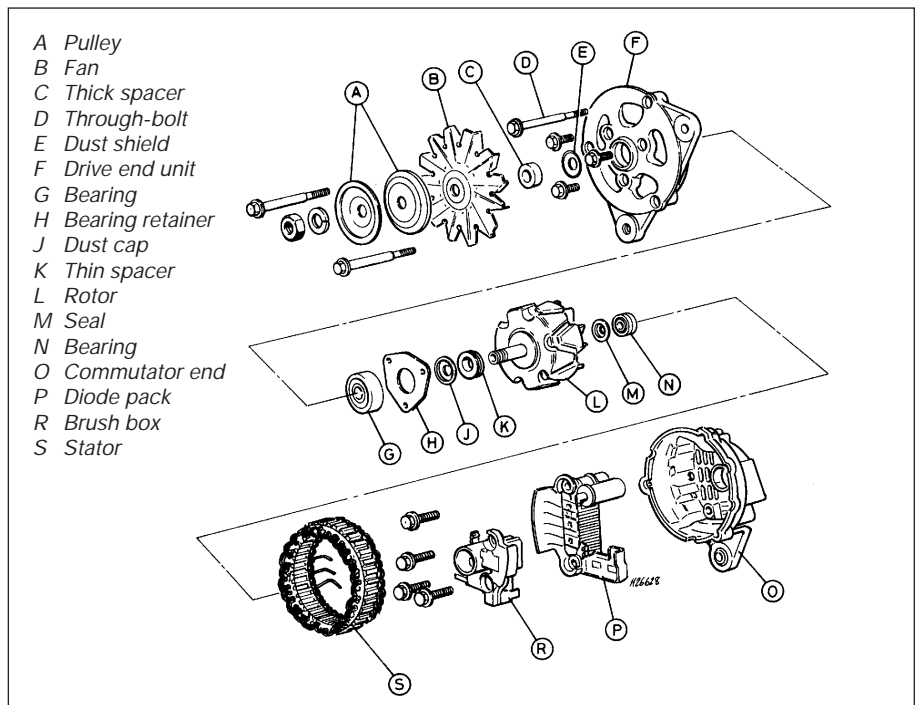

7.13a Exploded view of the Mitsubishi A5T alternator

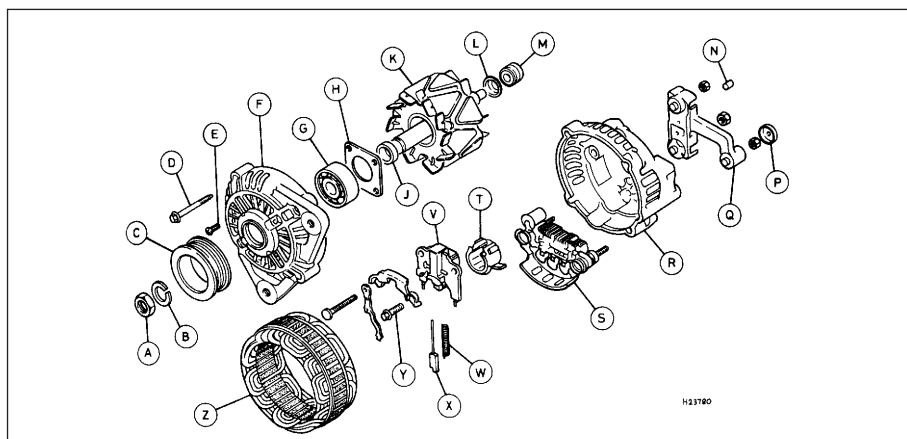

7.13b Exploded view of the AOO2T Mitsubishi alternator

- |                           |                         |                   |
|---------------------------|-------------------------|-------------------|
| A Pulley nut              | J Spacer                | S Rectifier       |
| B Spring washer           | K Rotor                 | T Dust cover      |
| C Pulley                  | L Spacer                | V Regulator       |
| D Through-bolt            | M Slip ring end bearing | W Brush spring    |
| E Retainer plate screw    | N Plug                  | X Brush           |
| F Drive end housing       | P Cap                   | Y Regulator screw |
| G Bearing                 | Q Terminal insulator    | Z Stator          |
| H Bearing retaining plate | R Slip ring end housing |                   |

14 Remove the rotor from the rear housing and the stator. If difficulty is experienced, heat the rear housing with a 200-watt soldering iron for three or four minutes.

15 Unbolt the rectifier/brush box and stator assembly from the rear housing (see illustration).

16 Unsolder the stator and brush box from the rectifier, using the very minimum of heat. Use a pair of pliers as a heat sink to reduce the heat transference to the diodes (overheating may cause diode failure).

17 Renew the brushes if they are worn down to, or beyond, the minimum specified length. Unsolder the brush wires at the points indicated (see illustration), then solder the new brush leads so that the wear limit line projects 2 to 3 mm from the end of the holder (see illustration).

18 Clean the slip rings with a solvent-moistened cloth, then check for signs of scoring, burning or severe pitting. If evident, the slip rings should be attended to by an automobile electrician.

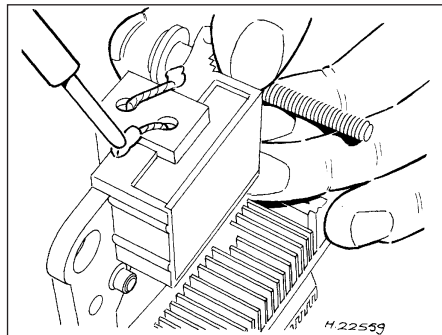

7.17a Unsoldering a brush wire on a Mitsubishi alternator

19 Refit in the reverse order of removal. Insert a piece of wire through the access hole in the rear housing to hold the brushes in the retracted position as the rotor is refitted (see illustration). Do not forget to release the brushes when assembled.

## 8 Starting system - testing

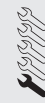

**Note:** Refer to the precautions in Section 1 before starting work.

1 If the starter motor fails to operate when the ignition key is turned to the appropriate position, the following possible causes may be to blame.

- The battery is faulty.
- The electrical connections between the switch, solenoid, battery and starter motor are somewhere failing to pass the necessary current from the battery through the starter to earth.
- The solenoid is faulty.
- The starter motor is mechanically or electrically defective.

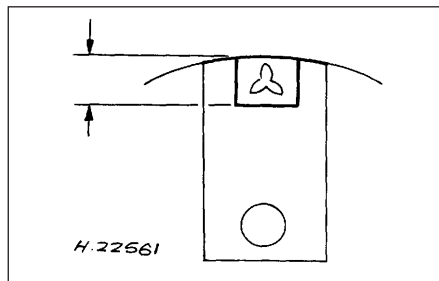

7.17b Fitted position of new brush on a Mitsubishi alternator

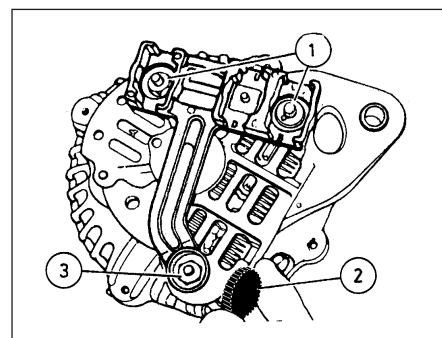

7.15 Rectifier/brush box (1) and regulator unit (3) retaining nuts on the Mitsubishi alternator. Note that cap (2) covers the regulator nut

2 To check the battery, switch on the headlights. If they dim after a few seconds, this indicates that the battery is discharged - recharge (see Section 3) or renew the battery. If the headlights glow brightly, operate the ignition switch and observe the lights. If they dim, then this indicates that current is reaching the starter motor, therefore the fault must lie in the starter motor. If the lights continue to glow brightly (and no clicking sound can be heard from the starter motor solenoid), this indicates that there is a fault in the circuit or solenoid - see following paragraphs. If the starter motor turns slowly when operated, but the battery is in good condition, then this indicates that either the starter motor is faulty, or there is considerable resistance somewhere in the circuit.

3 If a fault in the circuit is suspected, disconnect the battery leads (including the earth connection to the body), the starter/solenoid wiring and the engine/transmission earth strap. Thoroughly clean the connections, and reconnect the leads and wiring, then use a voltmeter or test lamp to check that full battery voltage is available at the battery positive lead connection to the solenoid, and that the earth is sound. Smear petroleum jelly around the battery terminals to prevent corrosion - corroded connections are amongst the most frequent causes of electrical system faults.

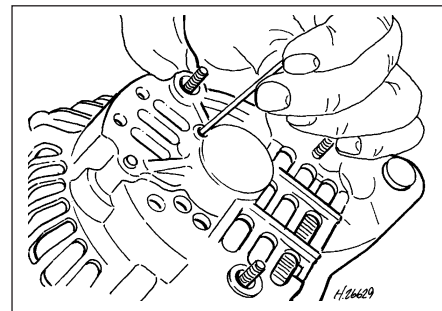

7.19 Use a length of wire rod to hold brushes in the retracted position when reassembling the rotor to the housing on the Mitsubishi alternator



9.4 Disconnecting the wires from the starter motor solenoid

4 If the battery and all connections are in good condition, check the circuit by disconnecting the wire from the solenoid blade terminal. Connect a voltmeter or test lamp between the wire end and a good earth (such as the battery negative terminal), and check that the wire is live when the ignition switch is turned to the "start" position. If it is, then the circuit is sound - if not the circuit wiring can be checked as described in Chapter 12.

5 The solenoid contacts can be checked by connecting a voltmeter or test lamp between the battery positive feed connection on the starter side of the solenoid, and earth. When the ignition switch is turned to the "start" position, there should be a reading or lighted bulb, as applicable. If there is no reading or lighted bulb, the solenoid is faulty and should be renewed.

6 If the circuit and solenoid are proved sound, the fault must lie in the starter motor. In this event, it may be possible to have the starter motor overhauled by a specialist, but check on the cost of spares before

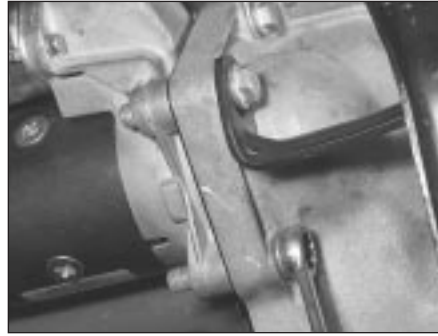

9.5a Starter motor retaining bolts

proceeding, as it may prove more economical to obtain a new or exchange motor.

## 9 Starter motor - removal and refitting

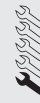

### Removal

- 1 Disconnect the battery negative (earth) lead (refer to Section 1).
- 2 Chock the rear wheels then jack up the front of the car and support it on axle stands (see "Jacking and vehicle support"). Remove the front roadwheels.
- 3 Undo the two retaining nuts, and remove the starter motor heat shield (where fitted).
- 4 Prise free the cap, if fitted, then unscrew the nuts to disconnect the wiring from the starter/solenoid terminals. Where applicable, disconnect the oxygen sensor wiring multi-plug from the locating bracket (see illustration).
- 5 Unscrew and remove the starter motor retaining bolts at the transmission/clutch

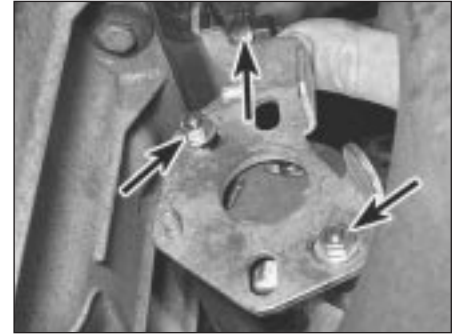

9.5b Starter motor rear support bracket and fasteners (arrowed)

housing and, where applicable, also unbolt and detach the support bracket. Withdraw the starter motor from its mounting, and remove it from the vehicle (see illustrations).

### Refitting

- 6 Refitting is a reversal of removal. Tighten the retaining bolts to the specified torque. Ensure that the wiring is securely reconnected to the starter motor (and solenoid) and is routed clear of the exhaust downpipe.

## 10 Starter motor - testing and overhaul



If the starter motor is thought to be suspect, it should be removed from the vehicle and taken to an auto-electrician for testing. Most auto-electricians will be able to supply and fit brushes at a reasonable cost. However, check on the cost of repairs before proceeding as it may prove more economical to obtain a new or exchange motor.

**Notes**